

The Tennis Rebounder is the largest rebound net in the tennis industry, measuring 7' tall, 6' wide, and 5' deep. Use this sheet to guide you through assembly and care to ensure years of enjoyment and practice. Open the box in the spacious area you will assemble the unit and check that all parts are ready for assembly.

#A	3 Longest length pipes	#E	2 “Y” shaped pipes
#B	4 Medium length pipes	#F	70 Net hooks
#C	2 Shortest length pipes	#G	18 Push-button clips to connect pipes
#D	6 Elbow shaped pipes	PLUS	1 Rebounder net

**STEP #1:** Assemble the frame as shown below, inserting the push-button clips as needed to connect the pipes together.

**STEP #2:** Using the enclosed net clips, attach the net on each side of the “Y” and then progressively connect the net to the frame working outwards from the middle starting point in all directions. Remember to alternate placing clips on each side of the frame as well as moving step-by-step in all three directions. Place the net clips 6” – 8” apart. To attach the net clips, loop the net around the small end of the clip and then snap the large portion of the clip over the desired position of the frame.

**STEP #3:** If for some reason the Rebounder twists during assembly, simply straighten it out with two people holding the frame, one on each side. Note that the frame and netting need a little while “to get to know each other” and then the frame, when carefully carried, will retain its shape for years.

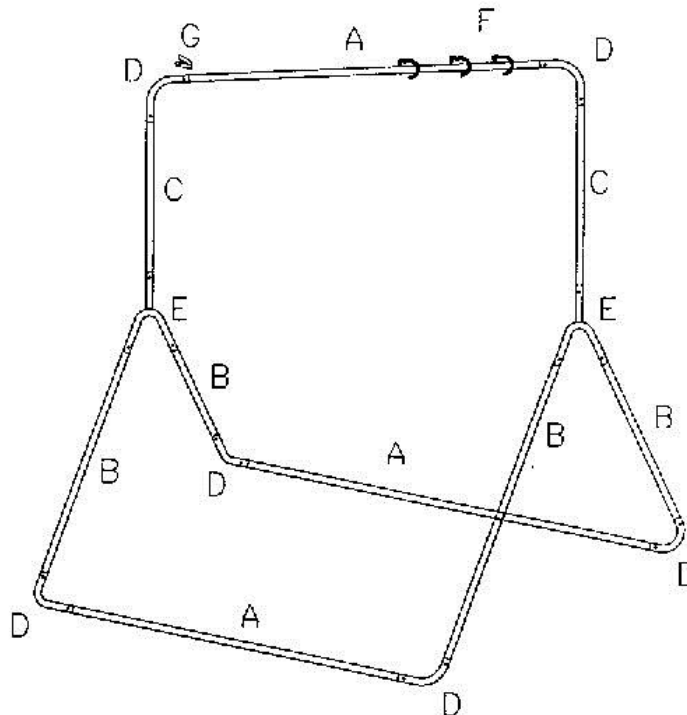

**DRILL IDEAS:** In addition to one person using the Rebounder like a backboard, two players can also hit simultaneously, one on each side of the net. You will also note that balls hit low into the angled section of the net will bounce upward, giving the hitter extended play. Finally, the Rebounder also offers excellent practice for high volleys. Hit the balls down into the lower angled portion of the Rebounder and the ball will pop back up, presenting the player with another chance to hit a high volley.